

**DOOSAN**

Construction Equipment

# DX225LCA

Engine Power	SAE J1995, gross 115 kW (154 HP) @ 1,900 rpm SAE J1349, net 110 kW (148 HP) @ 1,900 rpm
Operational Weight	21,500 kg (47,399 lb)
Bucket Capacity (SAE/PCSA)	0.39 ~ 1.51 m <sup>3</sup> (0.51 ~ 1.98 yd <sup>3</sup> )



# DOOSAN DX225LCA HYDRAULIC EXCAVATOR : A NEW MODEL WITH NOVEL FEATURES

## DX225LCA

### THE NEW DX225LCA HYDRAULIC EXCAVATOR HAS ALL THE ADVANTAGES

The new DX225LCA hydraulic excavator has all the advantages of the previous model, the Solar 225LC and now offers additional added value to the operator. The key phrase used during the development of the DX225LCA was “giving optimum value to the end user.”

#### 1. HEAVY-DUTY SPECIFICATION TO GUARANTEE MACHINE UPTIME

- Heavy duty boom & arm
- Double filtering system for moisture
- Air filter system has made the engine more adaptable to dusty area

#### 2. ENHANCE EASY ACCESS TO ALL COMPARTMENT

- In-house mechanical engine is easy to fix due to simple structure
- Filter locations are easily accessible at ground level

#### 3. BEST WORK EFFICIENCY

- Provide 3 working mode
- Operator can select proper working mode for best productivity





### 7 INCH MONITOR

- New, user-friendly LCD color monitor with full access to machine settings and maintenance data.



### CLIMATE CUSTOMIZED HYDRAULIC OILS (VG32, VG46, VG68)

- Maintain best performance by keeping optimum viscosity in various region



### ADVANCED FRONT BUSH

- EM bushing (Enhanced Macro-surface)
- Pocket & Dimple surface pattern : Optimized greasing & Trap foreign object
- Wear resistant solid lubricant coating : Noise free & enhanced anti-seizure property
- 30% longer life time than steel bush



### ADVANCED H-CLASS BUCKET

- Doosan new H-class bucket designed for higher productivity.
- Newly designed side cutter and abrasion resistant steel increase bucket solidity.



### HEAVY-DUTY FRONT

- Reinforced castings and forged steel pivot points and reinforced heavy-duty arm and boom to withstand high-impact materials.
- To better protect the base of the arm, reinforced bars have been added and the arm center and end boss have been strengthened.



### ROPS CERTIFIED CABIN (OPTIONAL)

- One of the most spacious cabs in the market, with low noise & vibration levels and excellent all-round visibility.
- Fully adjustable suspension seat, air conditioning with climate control as standard.



### PRE CLEANER

- Rotor type dry pre-cleaner an standard (Donaldson Top Spin 5")
- Separate more than 99% of particles of 20 micron and above particles.



### WATER SEPARATOR

- Large capacity of additional fuel water separator filters water in fuel and enhance engine's durability.



### ADVANCED UNDERCARRIAGE

- Strengthen Sprocket structure and tooth
- Structure to prevent debris

\* Option spec info is included to the images contained in this material and may not be the same with the actual specs.



# PERFORMANCE & PRODUCTIVITY

## DX225LCA

The performance of the DX225LCA has a direct effect on its productivity. Its new improved engine and new EPOS™ controlled hydraulic system have combined to create an unbeatable hydraulic excavator, with a cost/performance ratio that makes the DX225LCA even more appealing.



### DOOSAN ENGINE(DB58TIS)

Doosan product gives high performance through in-house engine

Doosan engine(In-house) perfectly harmonized with the hydraulic system and provides strong power. Mechanical engine provides high resistance to moisture, dust, and bad fuel quality. The best engine power in the industry(148HP) provides stable working speed even in the heavy workload situation.

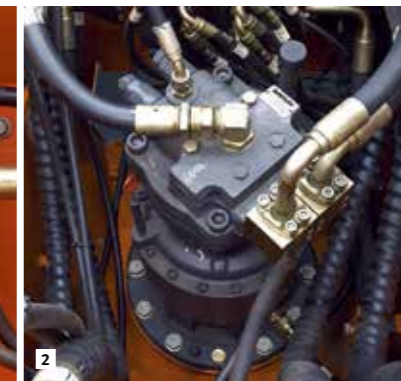
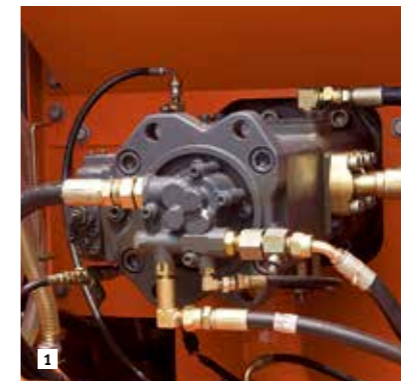

#### 1 HYDRAULIC PUMP

The Main pump has a capacity of 2x206.5l/min reducing cycle time while a high capacity gear pump improves pilot line efficiency.

#### 2 SWING DRIVE

Shocks during rotation are minimized, while increased torque is available to ensure rapid cycles.

#### 3 TRAVEL DEVICE

Travel device provides simple internal structure and increases efficiency of the performance. Thicker sprocket minimizes incoming debris and provides higher durability.

#### EXCAVATOR CONTROL

Improved Excavator control by New EPOS™ system  
The brains of the hydraulic excavator, the EPOS™ (Electronic Power Optimizing system), have been improved, through a CAN (Controller Area Network) communication link, these units are now perfectly synchronised.



# DURABILITY & RELIABILITY

## DX225LCA

The reliability of an item of plant contributes to its overall lifetime operating costs. DOOSAN uses computer-assisted design techniques, highly durable materials and structures then test these under extreme conditions.



### HEAVY DUTY BOOM & ARM BOOM (STANDARD)

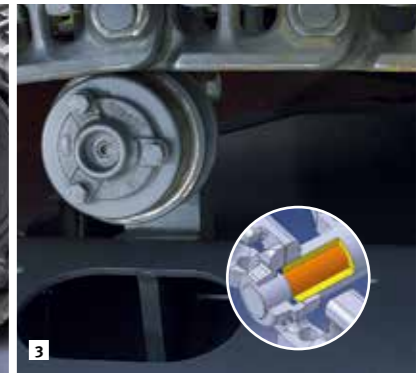
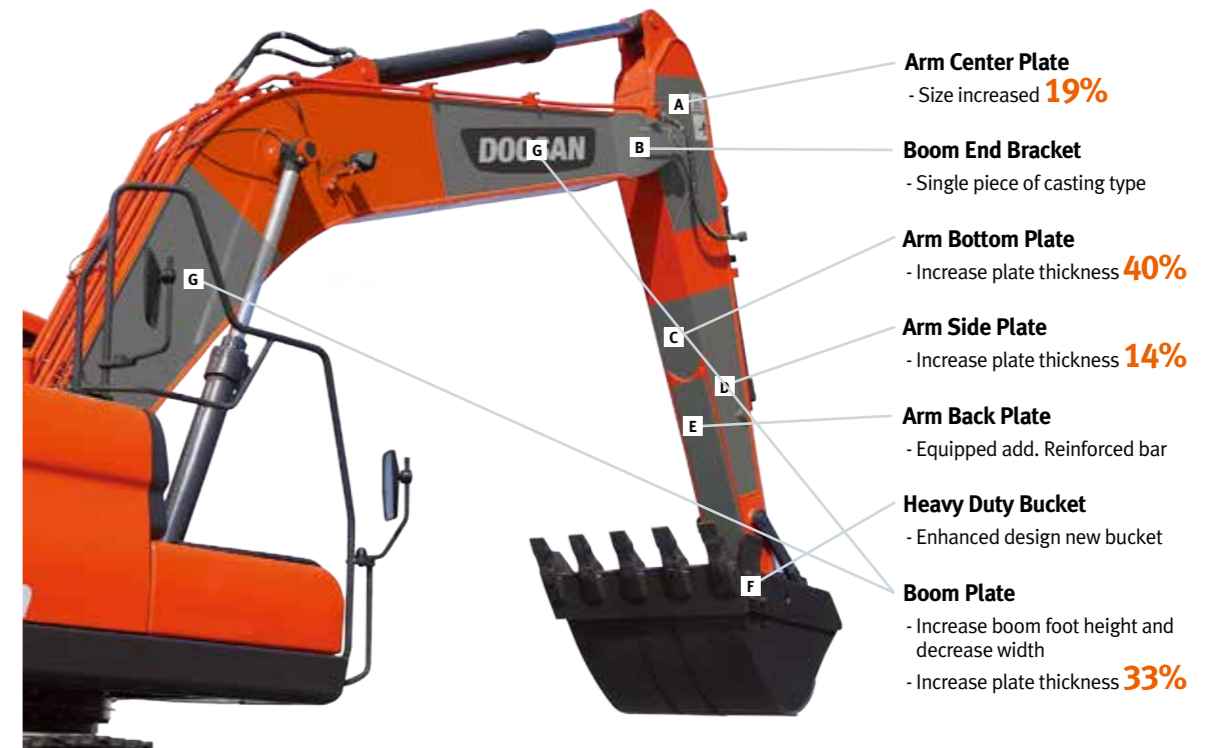

### 1 ADVANCED PIN-BUSH AND DISK / SHIM TECHNOLOGY

Pocket & Dimple surface pattern : Optimized greasing & Trap foreign object  
 - Wear resistant solid lubricant coating :  
 - Noise free & enhanced anti-seizure property.  
 - Polymer shim with hard metal disk (90% less abrasion)  
 - Hard metal anti-wear disk (75% less abrasion)

### 2 INTEGRATED TRACK SPRING AND IDLER

The track spring and the idler have been joined directly to achieve high durability and improved maintenance convenience.

### 3 TRACKS

The chain is composed of self-lubricating sealed links isolated from all external contamination. The tracks are locked by mechanically bolted pins.

### HEAVY DUTY & FIXED TRACK (OPTIONAL)

1. Idler Bracket  
- Thick & Wide strip to avoid bracket bending
2. Track Under Cover Plate  
- Reinforced track under cover (3.2T → 4.5T)  
- Reinforced mounting
3. Track Motor Cover  
- (Out) Add bolt head guard  
- (In) Reinforced motor cover mounting bolt using steel rib



**RELIEF CUTOFF**

The pump continues to supply flow even when the maximum pressure on the system is reached due to severe working environments and large workloads. Relief cutoff technology of DX225LCA prevents transfer of unnecessary flow to maintain powerful working level at the maximum value while reducing consumption of fuel.



**OPTIMIZED LEVER CONTROL & AUTO IDLE**

When operator takes a break and leaves the control joystick fixed, both of the engine and the pump are kept in standby mode and prevents unnecessary fuel consumption.



**PUMP MATCHING TECHNOLOGY**

Engine & pump matching, the new technology of Doosan, fully resolves problems; low responses time of the system, unnecessary fuel consumption. Matching response time between pump and engine efficiently reduces unnecessary fuel consumption as well as exhaust fumes.

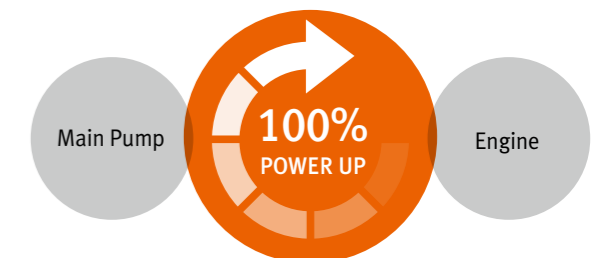
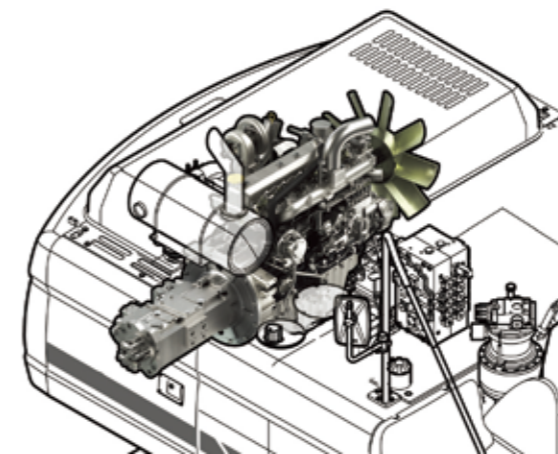



# OPERATOR COMFORT

# DX225LCA

More space, better visibility, air conditioning, a very comfortable seat. These are all elements that ensure that the operator can work for hours and hours in excellent conditions.



## MONITOR



- 3 power modes for maximum efficiency
- Power mode
  - Standard mode
  - Economy mode

1 Control panel

- 2 Navigation modes
- Rearview camera, Display selector

- 3 Working modes
- Auto-idle & Flow rate control

- 3 work modes to suit your application
- 1-way mode
  - 2-way mode
  - Digging mode



## CONTROL PANEL

- A Standard screen
- B Anti-theft protection
- C Filter/oil information
- D Operation history
- E Flow rate control
- F Contrast control



## 1 CONTROL LEVER

Very precise control of the equipment increases versatility, safety and facilitates tricky operations requiring great precision. Levelling operations and the movement of lifted loads in particular are made easier and safer. DOOSAN designed the DX225LCA by putting the operator at the center of the development goals. The result is significant ergonomic value that improves the efficiency and safety of the operator. More space, better visibility, air conditioning, a very comfortable seat... These are all elements that ensure that the operator can work for hours and hours in excellent conditions.

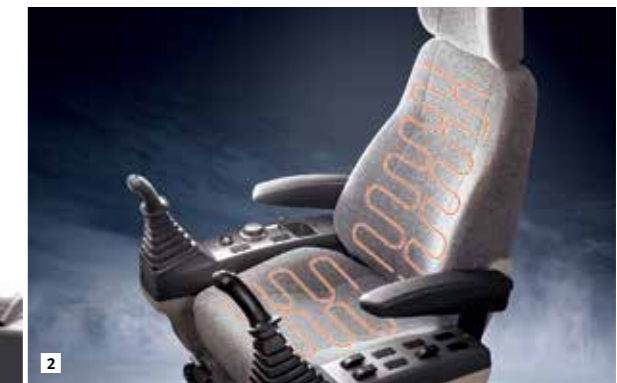

## 2 AIR SUSPENSION SEAT (OPTIONAL)

Equipped with various functions of adjustment forth and back and, and lumbar support, it reduces the vibration of equipment transmitted during work in an effective way. Also for considering winter working environment, Seat warmer functions equipped.



# EASY MAINTENANCE

# DX225LCA

Short maintenance operations at long intervals increase the availability of the equipment on site. DOOSAN has developed the DX225LCA with a view to high profitability for the user.



### 1 ENGINE OIL FILTER

The engine oil filter offers a high level of filtration allowing the oil change interval to be increased to 500 hours. It is easy to access and is positioned to avoid contaminating the surrounding environment.

### 2 EASY MAINTENANCE

Access to the various radiators is very easy, making cleaning easier. Access to the various parts of the engine is from the top and via side panels.

### 3 HYDRAULIC OIL RETURN FILTER

The protection of the hydraulic system is made more effective by the use of glass fiber filter technology in the main oil return filter. This means that with more than 99.5% of foreign particles filtered out, the oil change interval is increased.

### 4 AIR CLEANER

The large capacity forced air cleaner removes over 99% of airborne particles, reducing the risk of engine contamination and making the cleaning and cartridge change intervals greater.

### 5 WATER SEPARATOR

High efficiency and large capacity water separator protect the engine by removing most moisture from the fuel.

### 6 PC MONITORING (DMS)

A PC monitoring function enables connection to the EPOS™ system, allowing various parameters to be checked during maintenance, such as pump pressures, engine rotation speed, etc. and these can be stored and printed for subsequent analysis.

### 7 PRE CLEANER

Install rotor type pre-cleaner (Donaldson Top Spin 5"). So filtering efficiency 20% increased

### 8 CENTRALIZED GREASE INLETS FOR EASY MAINTENANCE

The boom & arm grease inlets are grouped for easy access.

\* Option spec info is included to the images contained in this material and may not be the same with the actual specs.



# TELEMATICS SERVICE (OPTIONAL)

# GLOBAL PARTS NETWORK

## TELECOMMUNICATIONS

Data flow from machine to web



**TELEMATICS SERVICE TERMINAL**

Telematics Service terminal is installed to machine / connected to EPOS™



**TELECOMMUNICATION**

GPS, EPOS™ data is sent to designated server by GSM, Satellite telecommunication

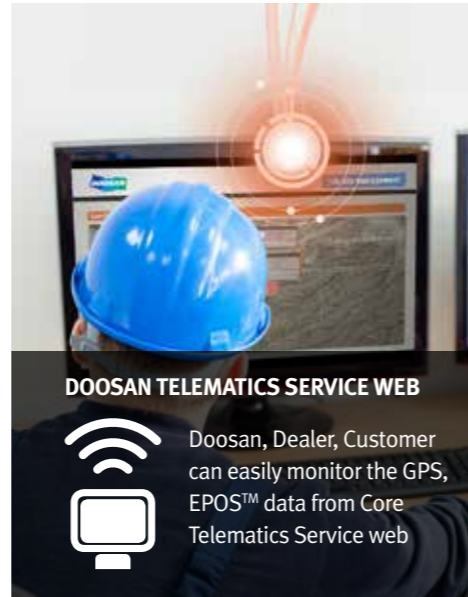

**DOOSAN TELEMATICS SERVICE WEB**

Doosan, Dealer, Customer can easily monitor the GPS, EPOS™ data from Core Telematics Service web

## FUNCTIONS

Doosan Telematics Service provides various functions to support your great performance

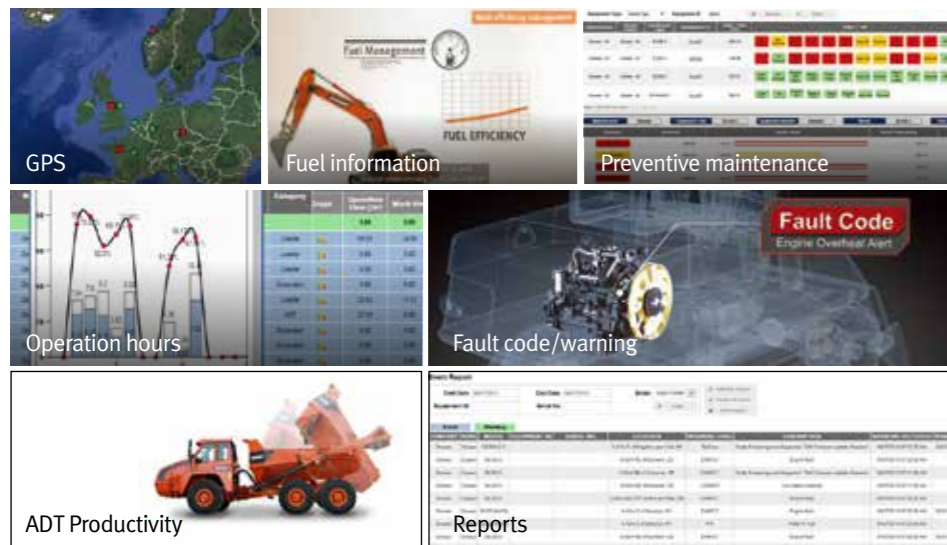

## TELEMATICS SERVICE BENEFITS

Doosan and dealer support customers to improve work efficiency with timely and responsive services

### Customer

- Improve work efficiency
- Timely and preventive service
- Improve operator's skills by comparing work pattern
- Manage fleet more effectively

### Dealer

- Better service for customers
- Provide better quality of service
- Maintain machine value
- Better understanding of market needs

### Doosan

- Responsive to customer's voice
- Utilize quality-related field data
- Apply customer's usage profile to developing new machine

## GLOBAL PDC (PARTS DISTRIBUTION CENTER) NETWORK

Doosan provides fast and precise worldwide delivery of genuine Doosan parts through its global PDC (parts distribution center) network.

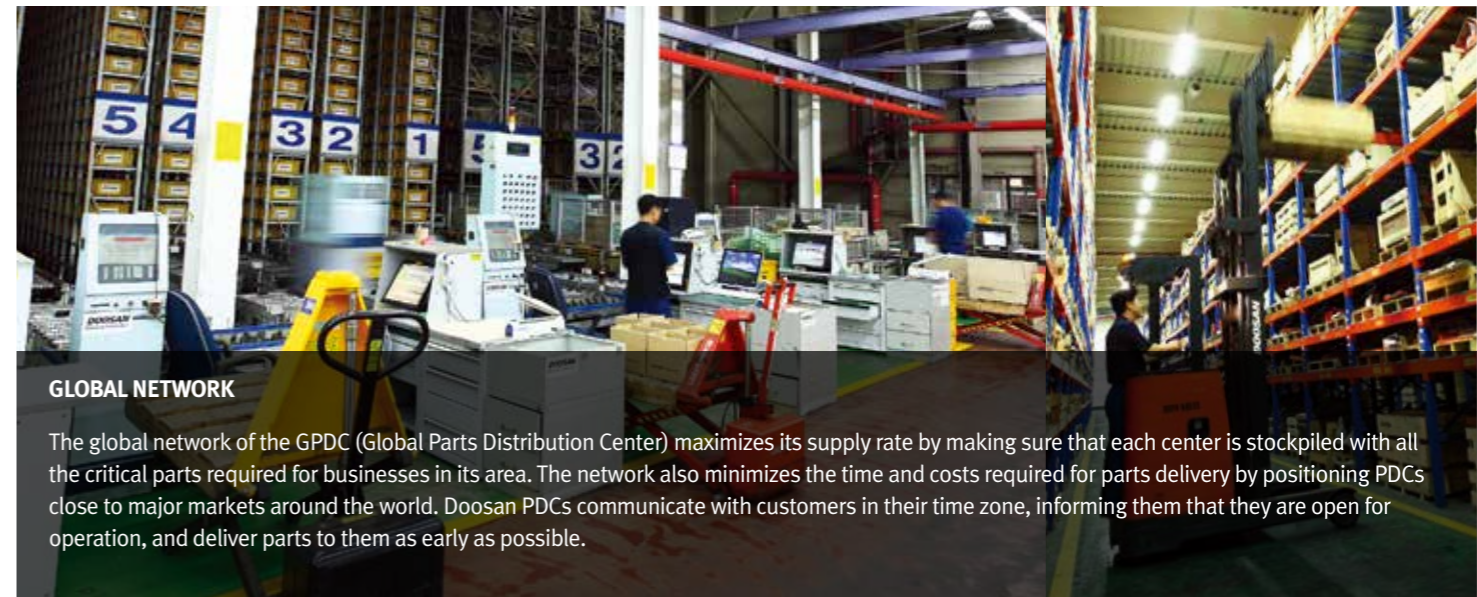

**GLOBAL NETWORK**

The global network of the GPDC (Global Parts Distribution Center) maximizes its supply rate by making sure that each center is stockpiled with all the critical parts required for businesses in its area. The network also minimizes the time and costs required for parts delivery by positioning PDCs close to major markets around the world. Doosan PDCs communicate with customers in their time zone, informing them that they are open for operation, and deliver parts to them as early as possible.

### The Global Parts Distribution Center Network

PDCs had been set up as shown below, including Mother PDC in Ansan, Korea. The nine other PDCs include one in China (Yantai), three in the USA (Chicago, Atlanta, Miami), one in Brazil (Americana), two in Europe (U.K. and Germany), one in the Middle East (Dubai) and one in Asia (Singapore)

(As of April, 2019)



MPDC : Mother Parts Distribution Center PDC : Parts Distribution Center

**PDC BENEFIT**

- Distribution Cost Reduction
- Maximum Parts supply rate
- Shortest distance/time parts delivery
- Real-time service support
- Minimum downtime

FUNCTION	EXCAVATOR	WHEEL LOADER	ADT
GPS	All models	All models	All models
E-mail reports	All models	All models	All models
Operation hours	All models	All models	All models
Maintenance parts	All models	Tier 4 only	All models
Fault code/ Warning	All models	Tier 4 only	All models
Fuel information	All models	Tier 4 only	All models
Dump capacity	N/A	N/A	All models

Heavy Construction Bucket, which is also called Heavy Duty bucket, is the most commonly used bucket in the construction equipment market and is designed mainly for use in heavy construction but also used in low density mining and quarry application.



### General Purpose bucket

which is also called General Purpose bucket, is designed for digging and re-handling soft to medium materials e.g. materials with low wear characteristics such as top-soil, loam, coal.



### Heavy Duty bucket

which is also called Heavy Duty bucket, is the most commonly used bucket in the construction equipment market and is designed mainly for use in heavy construction but also used in low density mining and quarry application.



### Severe Duty bucket

which is also called Severe Duty bucket. The bucket is designed for use in high density mining and quarry application using high strength and high abrasion resistance materials. It can be used in the toughest of applications.

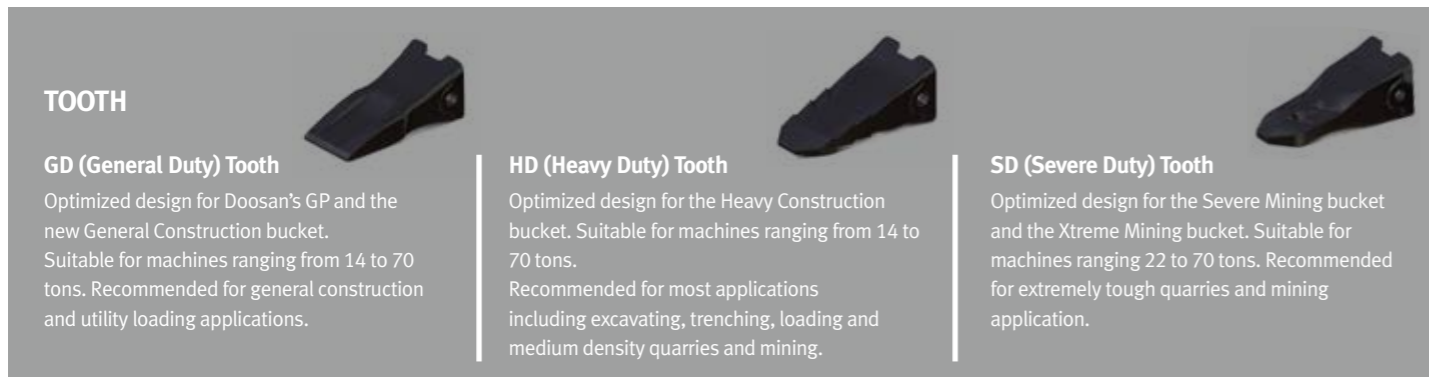

## BUCKET



	Capacity (SAE/PCSA)
<b>GENERAL PURPOSE BUCKET</b>	0.39 / 0.51 / 0.81/0.92/1.05/1.17 m <sup>3</sup>
<b>HEAVY DUTY BUCKET</b>	0.92 / 1.08 / 1.24 m <sup>3</sup>
<b>SEVERE DUTY BUCKET</b>	0.91 / 1.07 m <sup>3</sup>

## DEMOLITION



	Model	Weight	Tool diameter	Frequency
<b>HYDRAULIC BREAKER</b>	HB20	1,862 kg	135 mm	400~800 BPM
	Model	Weight	Max. Jaw opening	Force at Tip
<b>FIXED PULVERIZER</b>	FP22	1,375 kg	732 mm	54 t
<b>ROTATING CRUSHER</b>	RC22	1,780 kg	732 mm	56 t
<b>MULTI-PROCESSOR</b>	C / D / P / S MP22	2,040 / 2,050 / 2,210 / 1,880 kg	903 / 797 / 893 / 503 mm	68 / 70 / 64 / 80 t

C : Crushing jaw  
D : Demolition jaw  
P : Pulverizing jaw  
S : Shearing jaw

## MATERIAL HANDLING



	Model	Weight	Max Jaw opening	Max. Closing Force	Capacity
<b>MULTI-GRAPPLE</b>	MG22	1,423 kg	2,044 mm	5.7 t	0.75 m <sup>3</sup>
<b>STONE GRAPPLE</b>	SG22	1,470 kg	2,300 mm	-	0.45 m <sup>2</sup>
<b>WOOD GRAPPLE</b>	L / P WG22	1,450 / 1,190 kg	2,300 mm	-	0.62 m <sup>2</sup>
<b>LOG GRAPPLE</b>	L / P LG22	1,400 / 1,270 kg	2,095 / 2,225 mm	-	0.67 m <sup>2</sup>
<b>ORANGE GRAPPLE</b>	OG22	1,300 kg	2,150 mm	-	0.50 m <sup>2</sup>

L : Link type  
P : Pendulum type

## EARTH MOVING



	Model	Weight	Max. Jaw opening	Capacity
<b>CLAMSHELL BUCKET</b>	CB22	1,440 kg	2,080 mm	0.80 m <sup>3</sup>
	Model	Weight	Base plate (WxL)	Impulse force
<b>PLATE COMPACTOR</b>	PC22	1,094 kg	860 x 1,200 mm	11.2 t
	Model	Weight	Height	
<b>RIPPER</b>	RP22	450 kg	1,278 mm	

## CONNECTING



	Model	Weight	Bucket Pin dia.	Working rage (Pin to Pin)
<b>QUICK COUPLER</b>	QC22	319 kg	80 mm	445 ~ 514 mm

# TECHNICAL SPECIFICATIONS

## ENGINE

<b>Model</b>
Doosan DB58TIS 2 valves per cylinder, vertical injectors, water cooled, turbo charged with air to air intercooler. The emission levels are well below the values required for phase II.
<b>Number of cylinders</b>
6
<b>Nominal flywheel power</b>
115 kW (154 HP) @ 1,900rpm (SAE J1995, gross) 110 kW (148 HP) @ 1,900rpm (SAE J1349, net)
<b>Max torque</b>
61.5 kgf.m (603 Nm) at 1,400 rpm
<b>Piston displacement</b>
5,785 cc (353 cu.in)
<b>Bore &amp; stroke</b>
102 mm x 118 mm (4.0" x 4.6")
<b>Starter</b>
24 V / 4.5 kW
<b>Batteries</b>
2 x 12 V / 100 Ah
<b>Air cleaner</b>
Double element with auto dust evacuation.

## HYDRAULIC CYLINDERS

The piston rods and cylinder bodies are made of high-strength steel. A shock absorbing mechanism is fitted in all cylinders to ensure shock-free operation and extend piston life.

Cylinders	Quantity	Bore x Rod diameter x stroke
Boom	2	125 x 85 x 1,263 mm
Arm	1	140 x 100 x 1,443 mm
Bucket	1	120 x 80 x 1,060 mm

## WEIGHT

Boom 5,700 mm (18'8")    Arm 2,900 mm (9'6")    Bucket SAE/PCSA 0.92 m<sup>3</sup> (1.20 yd<sup>3</sup>)

	Shoe width	Operating weight	Ground pressure (kgf/cm <sup>2</sup> )
Triple Grouser	(Std) 600 mm (2')	21,500 kg (47,399 lb)	0.45 kgf/cm <sup>2</sup>
	700 mm (2' 4")	21,800 kg (48,060 lb)	0.40 kgf/cm <sup>2</sup>
	800 mm (2' 8")	22,100 kg (48,721 lb)	0.35 kgf/cm <sup>2</sup>
	900 mm (2' 11")	22,400 kg (49,383 lb)	0.31 kgf/cm <sup>2</sup>

## HYDRAULIC SYSTEM

The heart of the system is the EPOS™ (Electronic Power Optimizing System). It allows the efficiency of the system to be optimized for all working conditions and minimizes fuel consumption.

- The hydraulic system enables independent or combined operations.
- Two travel speeds offer either increased torque or high speed tracking.
- Cross-sensing pump system for fuel savings.
- Auto deceleration system.
- Two operating modes, two power modes.
- Button control of flow in auxiliary equipment circuits.
- Computer-aided pump power control.

### Main pumps

2 variable displacement axial piston pumps  
Max flow: 2 x 206.5 l/min

### Pilot pump

Gear pump - max flow: 28.5 l/min

### Maximum system pressure

Boom/arm/Bucket :  
Normal mode : 330 kgf/cm<sup>2</sup>  
Power mode : 350 kgf/cm<sup>2</sup>  
Travel : 330 kgf/cm<sup>2</sup>  
Swing : 270 kgf/cm<sup>2</sup>

## SWING MECHANISM

- An axial piston motor with two-stage planetary reduction gear is used for the swing.
- Increased swing torque reduces swing time.
- Internal induction-hardened gear.
- Internal gear and pinion immersed in lubricant bath.
- The swing brake for parking is activated by spring and released hydraulically.

**Swing speed : 0 to 11.0 rpm**

## UNDERCARRIAGE

Chassis are of very robust construction, all welded structures are designed to limit stresses.  
High-quality material used for durability.  
Lateral chassis welded and rigidly attached to the undercarriage.  
Track rollers lubricated for life, idlers and sprockets fitted with floating seals.  
Tracks shoes made of induction-hardened alloy with double grouser.  
Heat-treated connecting pins.  
Hydraulic track adjuster with shock-absorbing tension mechanism.

### Number of rollers and track shoes per side

Upper rollers : 2 (standard shoes)  
Lower rollers: 8  
Shoes : 49  
Total length of track : 4,445 mm (14' 7")

## DRIVE

Each track is driven by an independent axial piston motor through a planetary reduction gearbox.  
Two levers with control pedals guarantee smooth travel with counter-rotation on demand.

### Travel speed (fast/slow)

5.5 / 3.0 km/h (3.4 / 1.9 mph)

### Maximum traction force

11,500 / 21,800 kgf (25,353 / 48,061 lbf)

### Maximum grade

35° (70%)

## BUCKET

		TRACK	STD Track						
		C/W (ton)	4.1		5.3				
		SHOE (mm)	600						
Bucket Type	Capacity (m <sup>3</sup> )		Width (mm)		Width (kg)	5.7m Boom			SLR (8.5m)
	SAE/PCSA	CECE	W/O Cutter	With Cutter		2.4m HD Arm	2.9m HD Arm	3.5m Arm	SLR (6.2m)
GP	0.39	0.35	825	736	347	-	-	-	A
	0.51	0.47	768	722	549	A	A	A	X
	0.81	0.72	1,125	1,065	684	A	A	A	X
	0.92	0.81	1,233	1,173	724	A	A	A	X
	1.05	0.92	1,369	1,309	776	A	B	B	X
DC	0.54	0.46	1,800	-	358	-	-	-	C
H	0.92	0.83	1,050	1,096	867	A	A	B	-
	1.08	0.97	1,200	1,246	939	B	B	C	-
	1.24	1.11	1,350	1,396	1,011	C	C	D	-
S	0.91	0.82	1,050	1,094	1,078	A	B	C	-
	1.07	0.96	1,200	1,244	1,182	B	C	D	-
Maximum load pin-on(payload+bucket)						3153	2898	2686	1312

Based on ISO 10567 and SAE J296, arm length without quick change clamp  
A : Suitable for materials with density of 2,100 kg/m<sup>3</sup> (3,500lb/yd<sup>3</sup>) or less  
B : Suitable for materials with density of 1,800 kg/m<sup>3</sup> (3,000lb/yd<sup>3</sup>) or less  
C : Suitable for materials with density of 1,500 kg/m<sup>3</sup> (2,500lb/yd<sup>3</sup>) or less  
D : Suitable for materials with density of 1,200 kg/m<sup>3</sup> (2,000lb/yd<sup>3</sup>) or less  
X : Not recommended

This bucket recommendation is based on machine stability considering the tipping load with certain density of handling material, and should be strictly followed.  
It's more recommendable to use a smaller size of bucket than recommendation under the severe working condition and application to avoid the durability risks.

## ENVIRONMENT

Noise levels comply with environmental regulations (dynamic values).

### Sound level guarantee

103 dB (A) (2000/14/EC)

### Cab sound level

73 dB (A) (ISO 6396)

## REFILL CAPACITIES

### Fuel tank

400 l (105.7 US gal)

### Cooling system (Radiator capacity)

24 l (6.3 US gal)

### Engine oil

28.8l (7.6 US gal)

### Swing drive

5 l (1.32 US gal)

### Final drive

(each =Travel Device = travel motor + travel reduction gear)

2 x 4 l (2 x 1.06 US gal)

### Hydraulic tank

195 l (51.5 US gal)

# DIMENSIONS

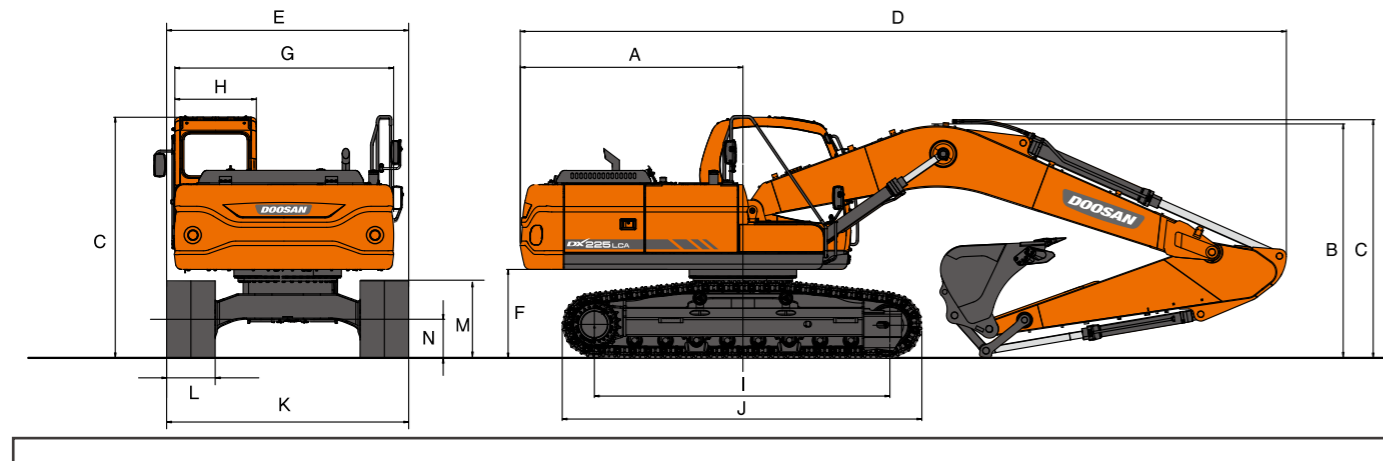

## DIMENSIONS

Boom 5,700 mm (18'8") Arm 2,900 mm (9'6") Shoe 600 mm (2') - Std

Boom type	5,700mm			8,500mm
Arm type	2,400mm	(Std.) 2,900mm	3,500mm	6,200mm
Bucket type (SAE / PCSA)	1.05m <sup>3</sup>	(Std.) 0.92m <sup>3</sup>	0.81m <sup>3</sup>	0.39m <sup>3</sup> ditch
A Rear Swing Radius	2,840mm	2,840mm	2,840mm	2,840mm
B Shipping Height (Boom)	2,860mm	2,960mm	3,209mm	3,306mm
C Shipping Height (Hose)	3,125mm	3,005mm	3,394mm	3,382mm
D Shipping Length	9,545mm	9,505mm	9,530mm	12,330mm
E Shipping Width	2,990mm	2,990mm	2,990mm	2,990mm
F Counterweight Clearance	*1066mm	*1066mm	*1066mm	*1066mm
G House Width	2,710mm	2,710mm	2,710mm	2,710mm
H Cabin width	1,010mm	1,010mm	1,010mm	1,010mm
I Tumbler Distance	3,650mm	3,650mm	3,650mm	3,650mm
J Track Length	4,446mm	4,446mm	4,446mm	4,446mm
K Undercarriage Width	2,990mm	2,990mm	2,990mm	2,990mm
L Shoe Width	600mm	600mm	600mm	600mm
M Track Height	*883mm	*883mm	*883mm	*883mm
N Ground Clearance	*450.5mm	*450.5mm	*450.5mm	*450.5mm

## DIGGING FORCE (ISO)

Bucket (SAE/PCSA)	0.51m <sup>3</sup>	0.81m <sup>3</sup>	(Std.) 0.92m <sup>3</sup>	1.05m <sup>3</sup>	1.28m <sup>3</sup>	0.54m <sup>3</sup> ditch
Digging force	15,200kgf	15,200kgf	15,200kgf	15,200kgf	15,200kgf	15,200kgf
	149.2kN	149.2kN	149.2kN	149.2kN	149.2kN	149.2kN
	33,510lbf	33,510lbf	33,510lbf	33,510lbf	33,510lbf	33,510lbf

Arm	2,400mm	(Std.) 2,900mm	3,500mm	6,200mm
Digging force	10.9ton	12.6ton	9.7ton	6.0ton
	107kN	123kN	95kN	59kN
	24,024lbf	27,770lbf	21,379lbf	13,224lbf

At power boost (ISO)

# WORKING RANGES

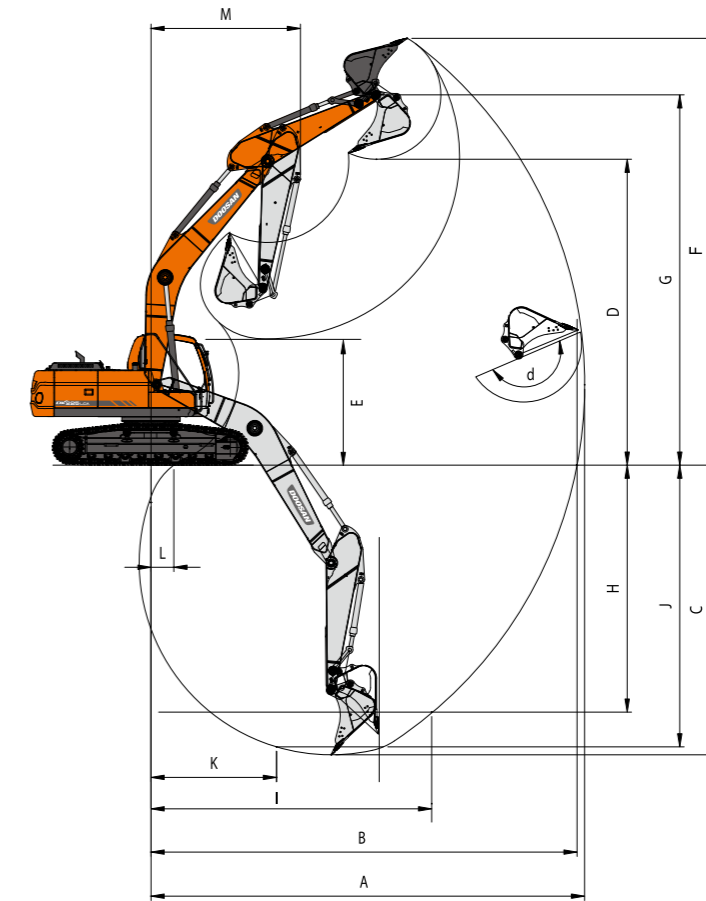

## WORKING RANGE

Boom length	5,700mm			8,500mm
Arm type	2,400mm	(Std.) 2,900mm	3,500mm	6,200mm
Bucket type (SAE / PCSA)	1.05m <sup>3</sup>	(Std.) 0.92m <sup>3</sup>	0.81m <sup>3</sup>	0.39m <sup>3</sup> ditch
A Max. digging reach	9,475mm	9,895mm	10,395mm	15,365mm
B Max. digging reach at ground level	9,295mm	9,705mm	10,230mm	15,255mm
C Max. digging depth	6,115mm	6,620mm	7,220mm	11,650mm
D Max. dumping height	6,665mm	6,805mm	6,950mm	11,660mm
E Min. dumping height	2,975mm	2,465mm	1,860mm	2,015mm
F Max. digging height	9,435mm	9,540mm	9,640mm	13,045mm
G Max. bucket pin height	8,125mm	8,270mm	8,405mm	12,050mm
H Max. vertical wall depth	4,480mm	4,765mm	5,105mm	8,385mm
I Max. radius vertical	7,025mm	7,335mm	7,705mm	11,440mm
J Max. digging depth(8' level)	5,910mm	6,435mm	7,050mm	11,560mm
K Min. radius 8' line	2,865mm	2,850mm	2,820mm	4,840mm
L Min. digging reach	1,762mm	599mm	-160mm	593mm
M Min. swing radius	3,575mm	3,570mm	3,615mm	4,970mm
d. Bucket angle (deg)	177°	177°	177°	171°

# LIFTING CAPACITY

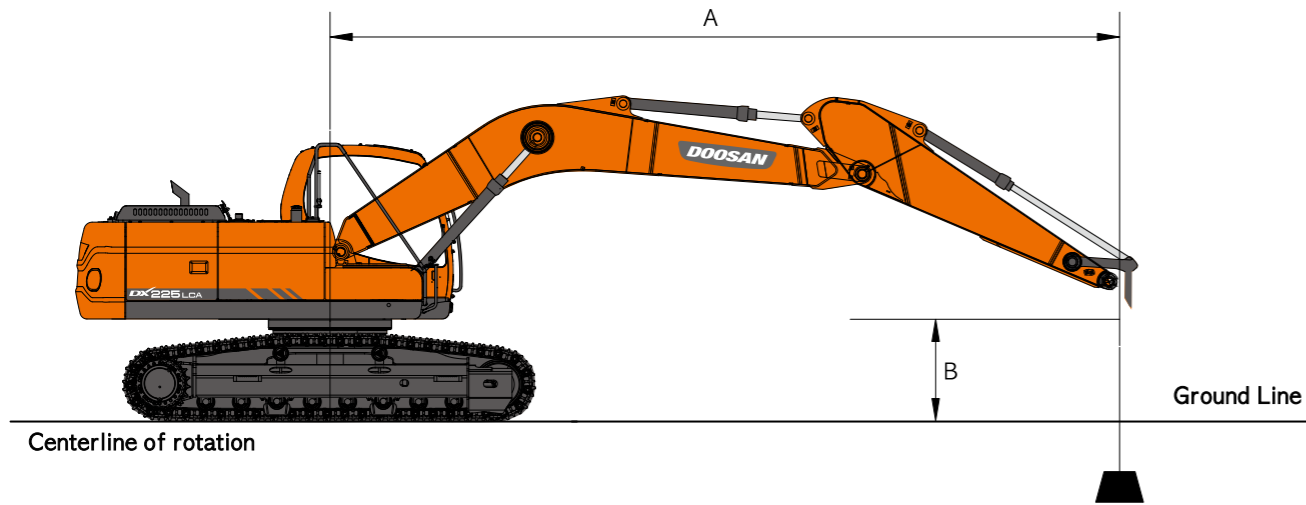

## STANDARD CONFIGURATION

### Metric

Boom : 5,700mm(HD) Arm : 2,900mm(HD) Without Bucket Shoe : 600mm Unit : 1,000kg

B(m)	1.5		3		4.5		6		7.5		Max. Reach		A(m)
	🔧	🔧	🔧	🔧	🔧	🔧	🔧	🔧	🔧	🔧	🔧		
7.5							4.88 *	4.88 *			4.25 *	4.25 *	6.20
6							5.33 *	5.18			3.96 *	3.68	7.31
4.5							5.84 *	5.01	5.37	3.48	3.90 *	3.11	7.99
3					8.55 *	7.29	6.65 *	4.74	5.25	3.37	4.00 *	2.83	8.35
1.5					10.15 *	6.75	7.18	4.48	5.11	3.25	4.27 *	2.72	8.42
0			6.10 *	6.10 *	10.91 *	6.46	6.97	4.3	5.01	3.15	4.39	2.77	8.22
-1.5	6.66 *	6.66 *	10.55 *	10.55 *	10.81 *	6.38	6.89	4.23	4.99	3.13	4.78	3.01	7.73
-3	11.36 *	11.36 *	13.75 *	12.64	9.87 *	6.46	6.94	4.28			5.71	3.58	6.88
-4.5			10.46 *	10.46 *	7.64 *	6.7					5.83 *	5.06	5.50

### Feet

Unit : 1,000lb

B(ft)	5'		10'		15'		20'		25'		Max. Reach		A(ft)
	🔧	🔧	🔧	🔧	🔧	🔧	🔧	🔧	🔧	🔧	🔧		
25							10.77 *	10.77 *			9.38 *	9.38 *	20.34
20							11.74 *	11.43			8.73 *	8.12	23.98
15							12.88 *	11.04	11.83	7.67	8.60 *	6.86	26.21
10					18.86 *	16.07	14.66 *	10.46	11.57	7.43	8.83 *	6.24	27.38
5					22.38 *	14.87	15.82	9.89	11.27	7.15	9.42 *	6	27.63
0			13.46 *	13.46 *	24.06 *	14.23	15.37	9.49	11.05	6.95	9.68	6.12	26.98
-5	14.68 *	14.68 *	23.25 *	23.25 *	23.84 *	14.06	15.19	9.33	10.99	6.9	10.55	6.64	25.36
-10	25.05 *	25.05 *	30.32 *	27.87	21.77 *	14.23	15.31	9.43			12.6	7.9	22.57
-15			23.07 *	23.07 *	16.84 *	14.78					12.85 *	11.16	18.05

- LOAD POINT IS THE END OF THE ARM.
- CAPACITIES MARKED WITH AN ASTERISK (\*) ARE LIMITED BY HYDRAULIC CAPACITIES.
- LIFT CAPACITIES SHOWN DO NOT EXCEED 75 % OF MINIMUM TIPPING LOADS OR 87 % OF HYDRAULIC CAPACITIES.
- THE LEAST STABLE POSITION IS OVER THE SIDE.
- LIFT CAPACITIES APPLY ONLY TO THE MACHINE AS ORIGINALLY MANUFACTURED AND NORMALLY EQUIPPED BY THE MANUFACTURER.
- THE TOTAL MASS OF MACHINE IS 20872 kg INCLUDED IN THIS MASS BOOM 5.7 m, ARM 2.9 m, 4115 kg COUNTERWEIGHT, ALL OPERATING FLUIDS AND A 75 kg OPERATOR.  
(THE TOTAL MASS OF MACHINE IS 46014.4112 lb INCLUDED IN THIS MASS BOOM 18' 8", ARM 9' 6", 9071.929 lb COUNTERWEIGHT, ALL OPERATING FLUIDS AND A 165.345 lb OPERATOR.)
- LIFT CAPACITIES ARE IN COMPLIANCE WITH ISO 10567.

🔧 : Rating Over Front

🔧 : Rating Over Side or 360 degree

## Option 1

### Metric

Boom : 5,700mm(HD) Arm : 2,900mm(HD) Without Bucket Shoe : 800mm Unit : 1,000kg

B(m)	1.5		3		4.5		6		7.5		Max. Reach		A(m)
	🔧	🔧	🔧	🔧	🔧	🔧	🔧	🔧	🔧	🔧	🔧		
7.5							4.88 *	4.88 *			4.25 *	4.25 *	6.20
6							5.33 *	5.31			3.96 *	3.78	7.31
4.5							5.84 *	5.13	5.39 *	3.57	3.90 *	3.2	7.99
3					8.55 *	7.47	6.65 *	4.86	5.39	3.46	4.00 *	2.91	8.35
1.5					10.15 *	6.92	7.37	4.61	5.25	3.34	4.27 *	2.8	8.42
0			6.10 *	6.10 *	10.91 *	6.63	7.17	4.43	5.15	3.25	4.52	2.86	8.22
-1.5	6.66 *	6.66 *	10.55 *	10.55 *	10.81 *	6.56	7.09	4.35	5.13	3.22	4.92	3.1	7.73
-3	11.36 *	11.36 *	13.75 *	12.98	9.87 *	6.63	7.14	4.4			5.88	3.69	6.88
-4.5			10.46 *	10.46 *	7.64 *	6.88					5.83 *	5.2	5.50

### Feet

Unit : 1,000lb

B(ft)	5'		10'		15'		20'		25'		Max. Reach		A(ft)
	🔧	🔧	🔧	🔧	🔧	🔧	🔧	🔧	🔧	🔧	🔧		
25							10.77 *	10.77 *			9.38 *	9.38 *	20.34
20							11.74 *	11.7			8.73 *	8.32	23.98
15							12.88 *	11.3	11.89 *	7.88	8.60 *	7.05	26.21
10					18.86 *	16.46	14.66 *	10.72	11.88	7.63	8.83 *	6.42	27.38
5					22.38 *	15.26	16.25	10.15	11.58	7.36	9.42 *	6.18	27.63
0			13.46 *	13.46 *	24.06 *	14.62	15.8	9.76	11.36	7.15	9.96	6.3	26.98
-5	14.68 *	14.68 *	23.25 *	23.25 *	23.84 *	14.46	15.62	9.6	11.31	7.1	10.85	6.84	25.36
-10	25.05 *	25.05 *	30.32 *	28.61	21.77 *	14.62	15.74	9.7			12.96	8.13	22.57
-15			23.07 *	23.07 *	16.84 *	15.17					12.85 *	11.45	18.05

## Option 2

### Metric

Boom : 5,700mm(HD) Arm : 2,400mm(HD) Without Bucket Shoe : 600mm Unit : 1,000kg

B(m)	3		4.5		6		7.5		Max. Reach		A(m)		
	🔧	🔧	🔧	🔧	🔧	🔧	🔧	🔧	🔧				
7.5											5.89 *	5.68	5.61
6							5.85 *	5.11			5.38 *	4.09	6.82
4.5					7.49 *	7.49 *	6.29 *	4.95	5.32	3.44	5.25 *	3.4	7.54
3					9.23 *	7.15	7.04 *	4.7	5.23	3.36	4.79	3.08	7.92
1.5					10.61 *	6.68	7.16	4.47	5.12	3.26	4.65	2.96	8.00
0					11.05 *	6.48	7	4.33	5.05	3.2	4.79	3.04	7.79
-1.5	10.42 *	10.42 *	10.65 *	6.46	6.96	4.3					5.29	3.35	7.27
-3	12.58 *	12.58 *	9.37 *	6.59	6.87 *	4.39					6.21 *	4.09	6.35
-4.5			6.32 *	6.32 *							5.61 *	5.61 *	4.82

### Feet

Unit : 1,000lb

B(ft)	10'		15'		20'		25		Max. Reach		A(ft)		
	🔧	🔧	🔧	🔧	🔧	🔧	🔧	🔧	🔧				
25											12.98 *	12.52	18.40
20							12.89 *	11.25			11.86 *	9.01	22.38
15					16.50 *	16.50 *	13.87 *	10.9	11.72	7.59	11.58 *	7.51	24.75
10					20.35 *	15.76	15.52 *	10.37	11.53	7.41	10.57	6.79	25.99
5					23.40 *	14.73	15.78	9.86	11.29	7.19	10.25	6.54	26.25
0					24.37 *	14.28	15.42	9.55	11.13	7.04	10.55	6.7	25.56
-5	22.96 *	22.96 *	23.48 *	14.25	15.34	9.47					11.67	7.38	23.84
-10	27.73 *	27.73 *	20.67 *	14.52	15.14 *	9.69					13.69 *	9.03	20.84
-15			13.92 *	13.92 *							12.36 *	12.36 *	15.82

# LIFTING CAPACITY

## Option 3

### Metric

Boom : 5,700mm(HD) Arm : 2,400mm(HD) without bucket Shoe : 800mm Unit : 1,000kg

B(m)	A(m)		3		4.5		6		7.5		Max. Reach		A(m)
7.5											5.89 *	5.81	5.61
6					5.85 *	5.23					5.38 *	4.19	6.82
4.5			7.49 *	7.49 *	6.29 *	5.07	5.46	3.53			5.25 *	3.5	7.54
3			9.23 *	7.33	7.04 *	4.82	5.38	3.45			4.93	3.16	7.92
1.5			10.61 *	6.86	7.35	4.6	5.26	3.35			4.78	3.05	8.00
0			11.05 *	6.66	7.19	4.45	5.19	3.29			4.92	3.13	7.79
-1.5	10.42 *	10.42 *	10.65 *	6.64	7.15	4.42					5.44	3.44	7.27
-3	12.58 *	12.58 *	9.37 *	6.77	6.87 *	4.52					6.21 *	4.21	6.35
-4.5			6.32 *	6.32 *							5.61 *	5.61 *	4.82

### Feet

Unit : 1,000lb

B(ft)	A(ft)		10'		15'		20'		25'		Max. Reach		A(ft)
25											12.98 *	12.82	18.40
20					12.89 *	11.52					11.86 *	9.24	22.38
15			16.50 *	16.50 *	13.87 *	11.17	12.04	7.79			11.58 *	7.71	24.75
10			20.35 *	16.16	15.52 *	10.64	11.85	7.61			10.86	6.97	25.99
5			23.40 *	15.12	16.21	10.13	11.61	7.39			10.54	6.72	26.25
0			24.37 *	14.68	15.85	9.82	11.45	7.25			10.86	6.89	25.56
-5	22.96 *	22.96 *	23.48 *	14.64	15.77	9.74					12	7.59	23.84
-10	27.73 *	27.73 *	20.67 *	14.91	15.14 *	9.96					13.69 *	9.28	20.84
-15			13.92 *	13.92 *							12.36 *	12.36 *	15.82

## Option 4

### Metric

Boom : 5,700mm Arm : 3,500mm without bucket Shoe : 600mm Unit : 1,000kg

B(m)	A(m)		1.5		3		4.5		6		7.5		Max. Reach		A(m)
7.5													3.59 *	3.59 *	6.87
6									4.32 *	3.64			3.40 *	3.32	7.89
4.5							5.34 *	5.13	5.00 *	3.57			3.37 *	2.86	8.52
3			11.73 *	11.73 *	7.77 *	7.52	6.21 *	4.86	5.32	3.44			3.47 *	2.62	8.85
1.5					9.58 *	6.92	7.13 *	4.57	5.16	3.3			3.70 *	2.52	8.92
0			7.36 *	7.36 *	10.71 *	6.54	7.02	4.35	5.03	3.18			4.03	2.55	8.74
-1.5	6.49 *	6.49 *	10.34 *	10.34 *	10.95	6.39	6.89	4.24	4.97	3.12			4.33	2.73	8.28
-3	10.09 *	10.09 *	14.91 *	12.48	10.40 *	6.4	6.89	4.23					5.01	3.16	7.49
-4.5	14.79 *	14.79 *	12.32 *	12.32 *	8.79 *	6.57	6.29 *	4.37					5.87 *	4.15	6.25

### Feet

Unit : 1,000lb

B(ft)	A(ft)		5'		10'		15'		20'		25'		Max. Reach		A(ft)
25													7.92 *	7.92 *	22.54
20									9.53 *	8.03			7.50 *	7.32	25.87
15							11.77 *	11.31	11.03 *	7.88			7.44 *	6.31	27.95
10			25.85 *	25.85 *	17.12 *	16.59	13.69 *	10.71	11.73	7.59			7.65 *	5.78	29.04
5					21.13 *	15.26	15.71 *	10.08	11.38	7.27			8.15 *	5.56	29.28
0			16.24 *	16.24 *	23.60 *	14.42	15.48	9.6	11.09	7.01			8.88	5.63	28.67
-5	14.32 *	14.32 *	22.81 *	22.81 *	24.14	14.08	15.2	9.34	10.95	6.87			9.54	6.03	27.16
-10	22.24 *	22.24 *	32.88 *	27.52	22.93 *	14.11	15.19	9.34					11.06	6.96	24.57
-15	32.61 *	32.61 *	27.15 *	27.15 *	19.38 *	14.48	13.88 *	9.64					12.93 *	9.15	20.50

## Option 5

### Metric

Boom : 5,700mm Arm : 3,500mm without bucket Shoe : 800mm Unit : 1,000kg

B(m)	A(m)		1.5		3		4.5		6		7.5		Max. Reach		A(m)		
7.5													3.59 *	3.59 *	6.87		
6												4.32 *	3.74	3.40 *	3.40 *	7.89	
4.5							5.34 *	5.25	5.00 *	3.66			3.37 *	2.94	8.52		
3					11.73 *	11.73 *	7.77 *	7.7	6.21 *	4.98			5.42 *	3.53	3.47 *	2.7	8.85
1.5							9.58 *	7.1	7.13 *	4.69			5.31	3.39	3.70 *	2.6	8.92
0					7.36 *	7.36 *	10.71 *	6.72	7.22	4.47			5.18	3.27	4.10 *	2.63	8.74
-1.5	6.49 *	6.49 *	10.34 *	10.34 *	10.97 *	6.56	7.09	4.36	5.11	3.21			4.45	2.82	2.82	8.28	
-3	10.09 *	10.09 *	14.91 *	12.82	10.40 *	6.58	7.08	4.36					5.16	3.25	7.49		
-4.5	14.79 *	14.79 *	12.32 *	12.32 *	8.79 *	6.75	6.29 *	4.49					5.87 *	4.27	6.25		

### Feet

Unit : 1,000lb

B(ft)	A(ft)		5'		10'		15'		20'		25'		Max. Reach		A(ft)	
25													7.92 *	7.92 *	22.54	
20												9.53 *	8.23	7.50 *	7.50 *	25.87
15							11.77 *	11.58	11.03 *	8.08			7.44 *	6.48	27.95	
10			25.85 *	25.85 *	17.12 *	16.98	13.69 *	10.97	11.95 *	7.79			7.65 *	5.94	29.04	
5					21.13 *	15.65	15.71 *	10.35	11.7	7.47			8.15 *	5.73	29.28	
0			16.24 *	16.24 *	23.60 *	14.81	15.91	9.86	11.41	7.21			9.04 *	5.8	28.67	
-5	14.32 *	14.32 *	22.81 *	22.81 *	24.18 *	14.47	15.63	9.61	11.27	7.08			9.82	6.21	27.16	
-10	22.24 *	22.24 *	32.88 *	28.25	22.93 *	14.5	15.62	9.6					11.37	7.17	24.57	
-15	32.61 *	32.61 *	27.15 *	27.15 *	19.38 *	14.87	13.88 *	9.91					12.93 *	9.41	20.50	



# STANDARD & OPTION

## STANDARD EQUIPMENT

### Boom & Arm

---

- 5.7m Boom (Heavy duty)
- 2.9m Arm (Heavy duty)

### Hydraulic system

---

- Boom and arm flow regeneration
- Boom and arm holding valves
- Swing anti-rebound valves
- Spare ports (Control valve)
- One-touch power boost

### Cabin & Interior

---

- Viscous cab mounts
- All weather sound suppressed type cab
- Air conditioner & Heater
- Adjustable suspension seat with head rest and adjustable arm rest
- Pull-up type front window and removable lower front window
- Room light
- Intermittent windshield wiper
- Cup holder
- Hot & Cool box
- LCD color monitor panel
- E/G RPM control dial
- AM/FM radio + MP3 (USB)
- Remote radio ON/OFF switch
- 12V,24V power socket
- Serial communication port for laptop PC interface
- Joystick lever with 3 switches

### Safety

---

- Large handrails and step
- Convex metal anti-slip plates
- Seat belt
- Hydraulic safety lock lever
- Safety glass
- Hammer for emergency escape
- Right and left rearview mirrors
- Travel alarm
- Battery protector cover (option)

### Others

---

- Double element air cleaner
- Additional water separator
- Dry type pre cleaner
- Fuel filter
- Dust screen for radiator/oil cooler
- Engine overheat prevention system
- Engine restart prevention system
- Self-diagnostic system
- 60A Alternator (24V, 50 amps)
- Electric horn
- Halogen working lights (frame mounted 1, boom mounted 2)
- Hydraulic track adjuster
- Track guards
- Greased and sealed track link
- Hydraulic oil tank air breather filter
- Long & Fixed track

## OPTIONAL EQUIPMENT

Some of optional equipments may be standard in some markets. Some of this optional equipment is not available in some markets. You must check with the local DOOSAN dealer to know about the availability or to release the adaptation following the needs of the applications

### Boom & Arm

---

- 5.7m Boom
- 8.5m Boom
- 2.4m Arm (Heavy duty)
- 2.9m Arm
- 3.5m Arm
- 6.2m Arm

### Safety

---

- Boom and arm hose rupture protection valve
- Overload warning device
- Cabin Top/Front guard (ISO 10262, FOGS standard)
- Travel & swing alarm
- Rotating
- Rear lamp for number plate

### Cabin & Interior

---

- Air suspension seat
- Rain Shield
- High seat Mount
- Breaker pedal
- ROPS/FOGS Cabin
- Cabin front guard (Upper and lower guard)
- Steel roof cover
- Additional mirror

### Others

---

- Piping option
  - Piping for Crusher
  - Piping for Breaker
  - Piping for Quick clamp
  - Piping for Rotating
- 700mm / 800mm / 900mm shoe
- Lower wiper
- 60A/80A alternator
- Fuel filler pump
- Working Lights
  - 4-front / 2-rear on cabin
  - 2-front on cabin
  - 1 on counterweight
- Counterweight (3.8 Ton / 5.3 Ton)
- Hydraulic Oil
  - Cold weather (VG32)
  - Normal (VG46)
  - Tropical weather (VG68)
- Breaker filter
- Water separator with heater
- Heavy duty under cover
- Short & Fixed track
- Heavy duty & Fixed track



# Doosan is

Since 1896, Doosan, the oldest company in Korea, has evolved with its people. The company grew up rapidly for last 10 years with reputation. For human-oriented vision, Doosan has been building constructions, energy, machines, infra structures globally. As a global leader of infra structure, Doosan continues its vision to make human-oriented future.

First in Korea, Doosan self-developed excavators in 1985 and continued building versatile construction machines including excavators, wheel loaders, articulated dump trucks to execute its human-oriented philosophy. Doosan became a global leader of heavy construction machine industry by achieving global sales line, producing line, and distribution line. Along with large production bases in Korea, China, USA, Belgium, Czech, Doosan has 1400 dealer networks and Doosan is providing reliable products and trusted solutions for your stable business at no risk.



DIPBE-01-2001

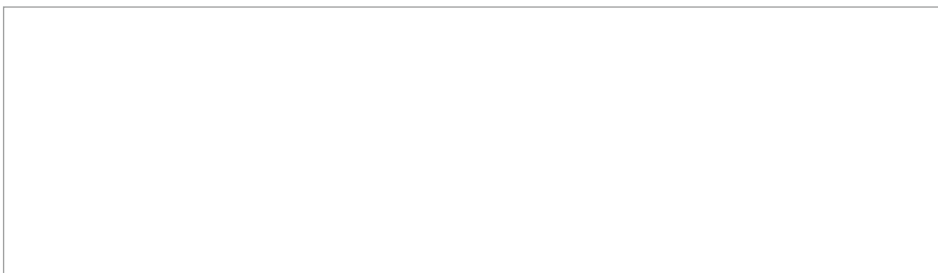

**Doosan Infracore Co., Ltd.**  
489 (Hwasu-dong), Injung-ro, Dong-Gu,  
Incheon, Korea (22502)  
<https://global.doosanequipment.com>

Copyright 2020. Doosan Infracore. All rights reserved.

